

# TECHNICAL DATA

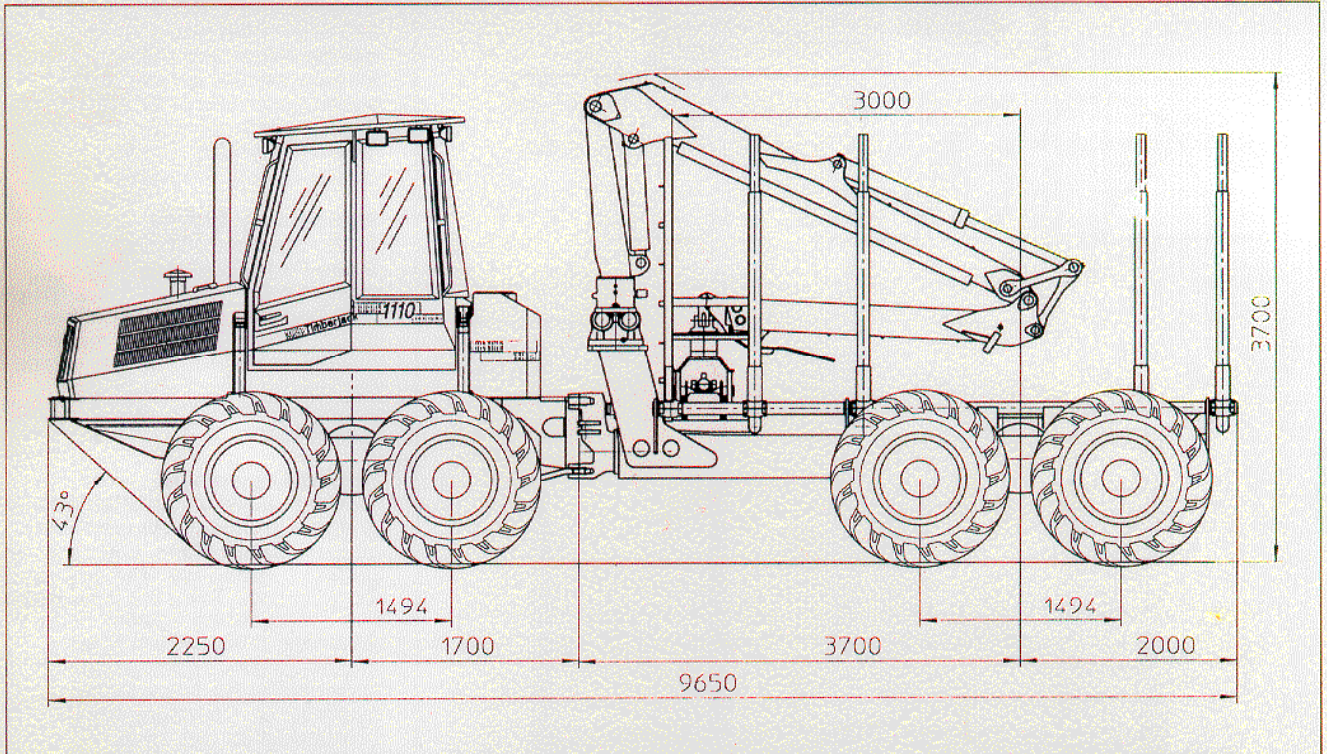

### Dimensions

Length 9650 mm  
 Width 2680 mm (600 tires),  
 2860 (700 tires)  
 Transportation height 3700 mm  
 Ground clearance 605 mm 6-wh,  
 605 mm 8-wh  
 Wheelbase 5400 mm.

### Weight

6-wh 12,600-13,900 kg depending on  
 options, 8-wh 14,300-15,700 kg  
 depending on options.

### Load Area

Length 4910 mm for 2x2.5 m.  
 Width 2560 mm.  
 Cross section:  
 3.0 m<sup>2</sup> for logs longer than 4 m,  
 4.0 m<sup>2</sup> for logs shorter than 4 m.  
 Load rating 11,000 kg.

### Engine

Perkins 1006-6T water-cooled  
 turbocharged 6-cylinder diesel  
 engine. Output 114 kW(155 hp)/  
 2200 rpm. Max. torque 511 Nm/1600  
 rpm. Fuel tank 150 l.

### Transmission

Timberjack TMC (Total Machine  
 Control) system. Hydrostatic-  
 mechanical power transmission.  
 Range gear with low and high range.  
 Inching, smooth start through pedal  
 without dropping engine revolutions.  
 Travel speed max. 25 km/h.  
 Max. tractive force 150 kN.

### Axles

Bogie axles with portal type bogie  
 beams, including patented balancing  
 units. Similar axles at front and rear on  
 8-wh. Power transmission through  
 gears in the bogie beams.  
 Hydraulically operated mechanical  
 differential locks front and rear.  
 Disconnection of rear axle drive with  
 high range.

### Steering

Articulated frame steering with two  
 hydraulic steering cylinders.  
 Steering angle  $\pm 44^\circ$ .  
 Proportional steering with electric  
 joystick.

### Tires

6-wh front 600-34 and rear 600-26.5,  
 optional front 700-34 and  
 rear 700-26.5.  
 8-wh 600-26.5, optional 700-26.5.

### Brakes

Service and working brakes are  
 hydraulically actuated, oil immersed  
 multiple disc brakes. Identical in  
 both axles. Spring actuated  
 parking and emergency brakes  
 in front and rear bogie.

### Hydraulic system

Timberjack TMC system. Load-  
 sensing hydraulic system with  
 power control. Working pressure  
 21.5 MPa. Pump capacity: working  
 hydraulics 280 l/min, power  
 train 220 l/min. Hydraulic oil  
 reservoir volume 140 l.

### Electrical system

Voltage 24 V. Batteries 2x110 Ah.  
 Alternator 100 A/28 V.  
 Working lights 8x140 Twin Power.

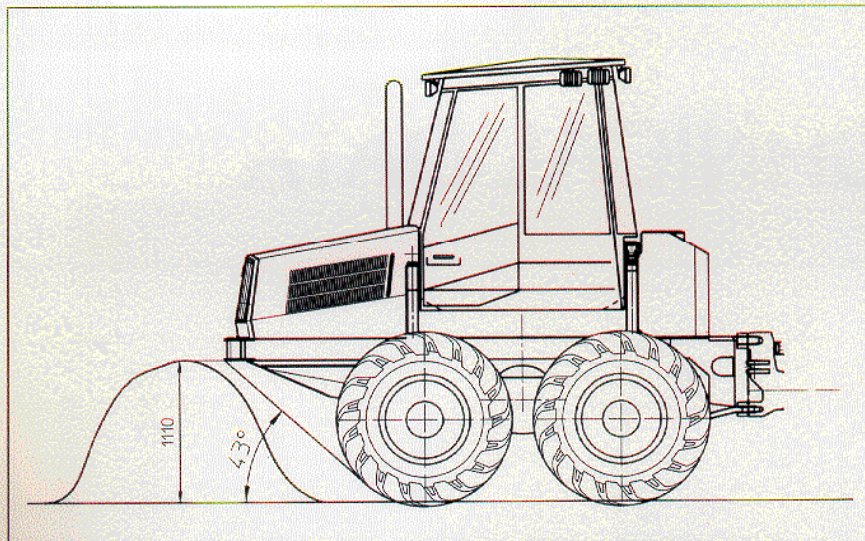

#### Loader

F71 F72

Lift moment gross 99 kNm.  
Reach 7.2 m, optional 8.5 m.

#### Cab

Spacious, light and comfortable cab offers excellent visibility in all directions. Efficient heating and air-conditioning. Unique mounting of the cab ensures exceptionally low noise vibration levels. Noise level meets ISO 5131:1993 below 70 dB(A). Cab can be raised and shifted to the side for easy service access. Safety tested according to ISO standards. Radio/cassette recorder. Connection for cellular phone. Tinted polycarbonate windows.

#### Standard equipment

Tools. Operator's Manual. Spare Parts Catalogue. Fire extinguisher. Travel distance gauge (TMC system). Constant engine revolution regulator (TMC system). Stability brake. Mechanical engine oil extraction pump. Exhaust pipe support. Mechanical refill pump for hydraulic oil.

#### Optional equipment

Exhaust catalytic converter. Engine and cab preheater. Air cushioned seat. Hydraulic steps. Electrical refill pump for hydraulics. Vacuum pump for hydraulics. Extra fire extinguisher. Fire Extinguishing System, night automatic or Fire Alarm System. Tracks. Chains. Spare wheel. Dozer blade. Biodegradeable hydraulic oil. Clambunk fittings. Loadstakes for 3x1.15 m. Engine hood protection and steel wire branch protection. Working lights: 2x70W on loader. Working lights: 2x70W on lower corner of cabin and 1x70W rear light. Portable electrical refill pump for fuel.

All rights to alterations reserved.

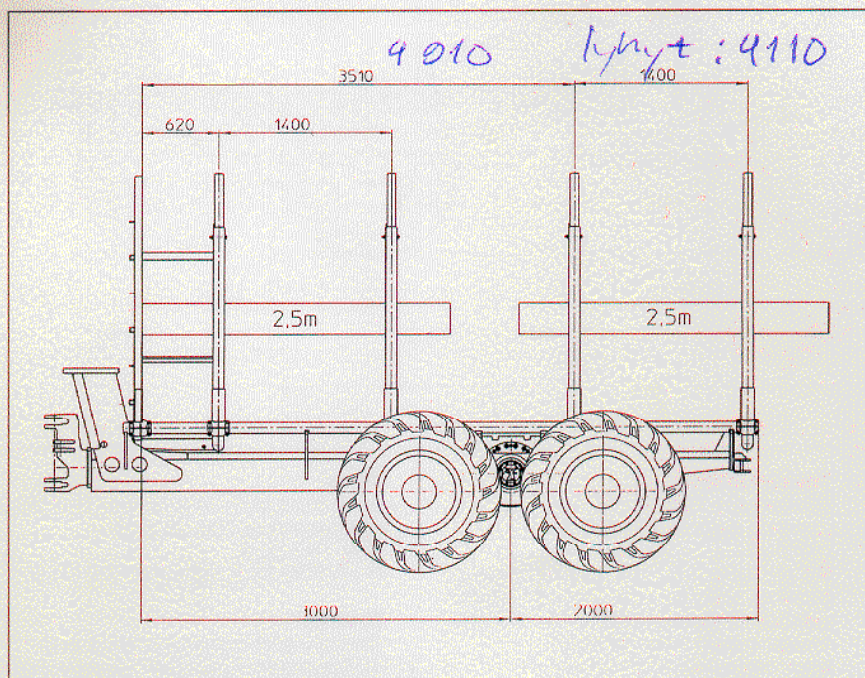

Timberjack Europe  
P. O. Box 474  
FIN-33101 Tampere, Finland  
Tel +358 31 241 0111  
Fax +358 31 241 0290

# Timberjack