

Timberjack 1110C Forwarder

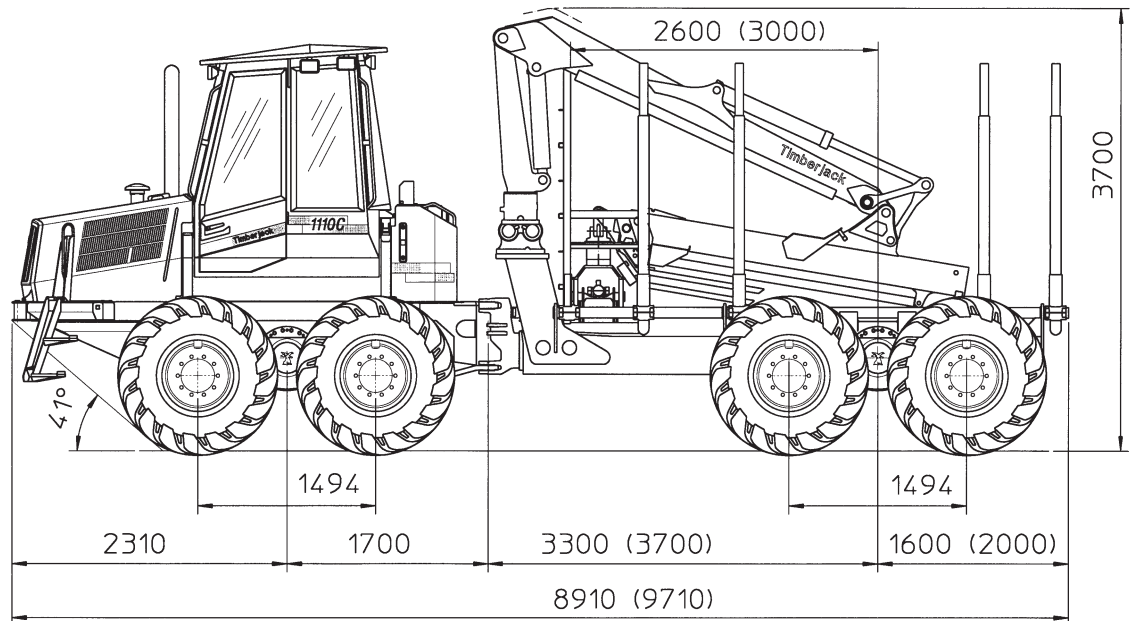

Technical Data

Dimensions

Length	9710 mm
optional	8910 mm
Width	2860 mm (700-tires)
optional	2680 mm (600-tires)
Transport height	3700 mm
Ground clearance	605 mm
Wheelbase	5400/5000 mm
Load rating	11 000 kg

Weight

Depending on equipment	
6-wheel	12 600 kg – 13 900 kg
8-wheel	14 300 kg – 15 700 kg

Load space

Length	5000 mm
optional	4200 mm
Width	2795 mm
Cross sectional area	4,0 m ²
Hydraulically movable headboard 4 bunks, 8 stakes	

Engine

Perkins 1006-60T, water-cooled turbo-charged 6-cylinder diesel engine	
Output	113 kW / 2200 rpm
Max. torque	620 Nm / 1500 rpm
Fuel tank capacity	150 l

Transmission

Timberjack TMC® (Total Machine Control) -system. Hydrostatic-mechanical power transmission. Range gear with low and high range. Power distributed between the front and rear axles. Off-road driving, smooth no-surge start without dropping engine speed. Release of rear-wheel drive. Travel speed max. 23 km/h. Max. tractive force 150 kN.

Axles

Bogie axles with portal type bogie beams including patented balancing units. Similar axles at front and rear on 8-wheel. Hub planetaries in 6-wheel front axle. Power transmission through gears in bogie beams. Hydraulically operated mechanical differential lock in front and rear. Disconnection of rear axle with high range.

Steering

Articulated frame steering with two hydraulic steering cylinders. Steering angle $\pm 44^\circ$. Proportional steering with electric joystick.



Electrical system

Voltage	24 V
Batteries	2 x 115 Ah
Alternator	140 A / 28 V
Working lights	10 x 140 TwinPower

Vacuum pump
Exhaust pipe support
Spare parts catalogue/Operator's manual
Decals in English

Optional equipment

Biodegradable hydraulic oil
Separate 550 l fuel tank
Electrical refill pump for hydraulics
Decking blade
Sun blinds in all windows
Preheater 4.0 kW: engine, cabin
Portable electrical fuel refill pump
Back-up-alarm
Preparedness for clambunk
Wipers on rear side windows
Chains, tracks
Spare wheels and wheel rims

Loader TJ 71 F

General for loader

In all types the slew torque is 24,4 kNm with the angle 380° and the gross lifting moment 99 kNm.

TJ 71 F 72	
Reach	7,2 m
Length of extension	1400 mm
Max. load at max. outreach	1080 kg

(optional)	
TJ 71 F 85	
Reach	8,5 m
Length of extension	2650 mm
Max. load at max. outreach	800 kg

(optional)	
TJ 71 F 100	
Reach	10 m
Length of extension	4200 mm
Max. load at max. outreach	580 kg

The manufacturer reserves the right to make changes or add improvements without incurring any obligation to make such changes on machines manufactured previously.

Tires	8 W	6 W
Front	700/26,5/16	700/34/14
optional	600/55x26,5/16	600x65x34/14
Rear	700/26,5/16	700/26,5/16
optional	600/55x26,5/16	600/55x26,5/16

Brakes

Service and working brakes are hydraulically actuated, oil immersed multiple disc brakes. Identical in both axles. Spring actuated parking- and emergency brakes in front and rear bogies. According to ISO 11169.

Hydraulic system

Timberjack TMC® -system. Load-sensing hydraulic system with power control.	
Pressure	21,5 Mpa
Pump volume	125 cc
Hydraulic oil reservoir	140 l

Cab

Spacious, light and comfortable cab giving the operator excellent vision in all directions. Efficient heating and air conditioning. The cab meets ISO standards for ROPS, FOPS, OPS. Thanks to the unique mounting of the cab, the noise level and vibrations are low. Noise level below 70 dB(A) (according to ISO 5131:1993). The cab can be raised and shifted to the side for easy service access. Radio/cassette receiver. Connection for cellular phone. Tinted polycarbonate windows. Air cushioned seat with air locked seat swivel.

Standard equipment

Timberjack TMC® (Total Machine Control)
Fire extinguisher ABE
Sprinkler system
Tow hook
Mechanical refill pump for hydraulics
Engine oil drain hose
Mineral hydraulic oil
Hydraulic steps
Neck support

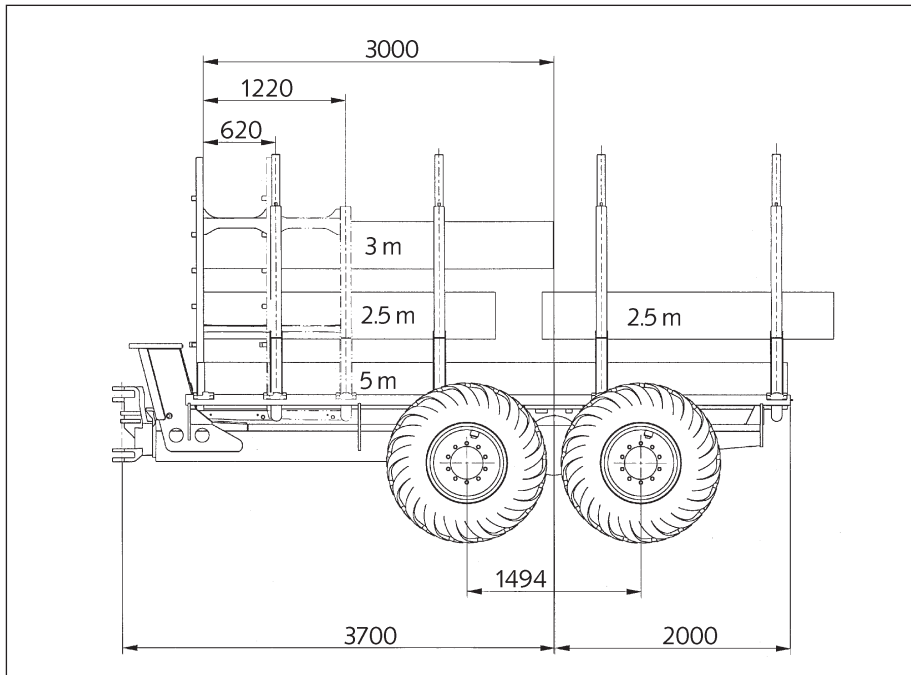

Timberjack

Doing more

www.timberjack.com