

## TECHNICAL DATA

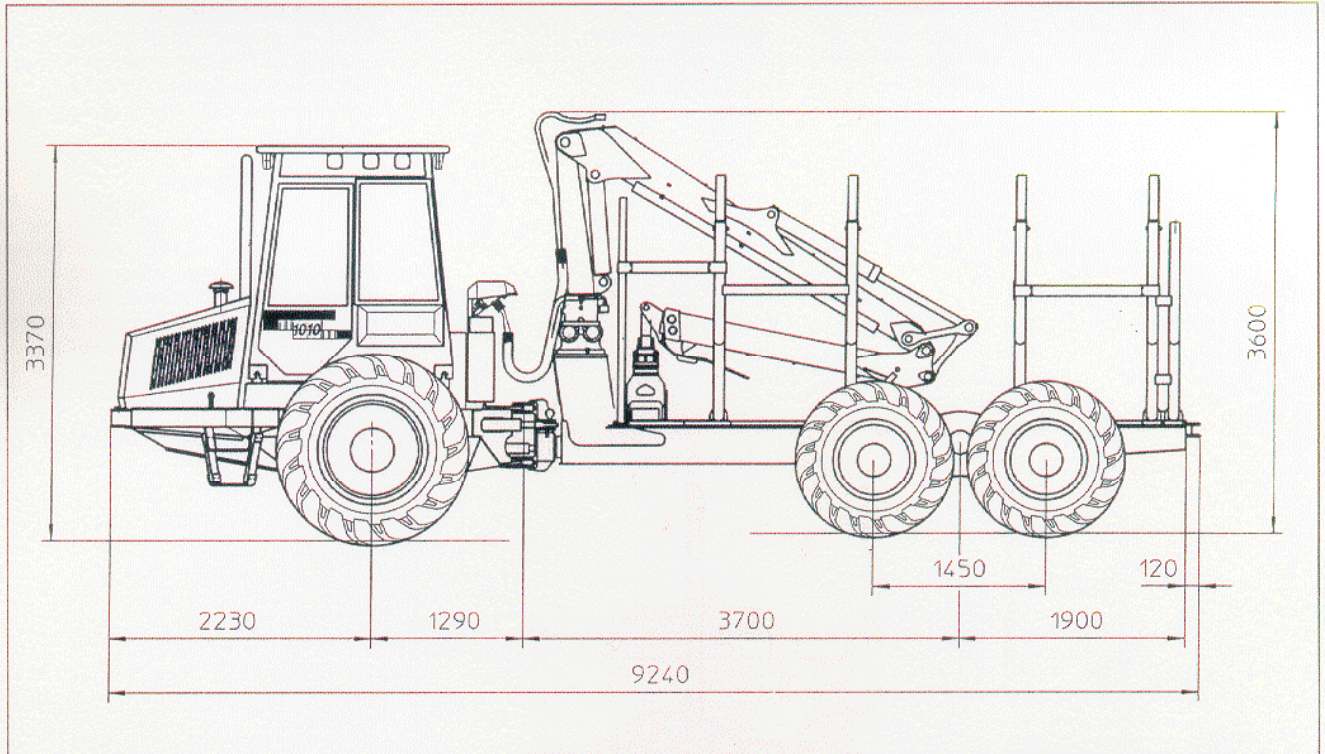

### Dimensions

|                       |  |
|-----------------------|--|
| Length                | 9240 mm                                    |
| Width                 | 2680 mm (600 tires)<br>2880 mm (700 tires) |
| Transportation height | 3600 mm                                    |
| Ground clearance      | 600 mm                                     |
| Wheelbase             | 4790 mm                                    |

### Weight

11,400–12,300 kg depending on options.

### Load Area

Length 4630 mm for 2x2.5 m  
Width 2480 mm  
Cross section:  
2.7 m<sup>2</sup> for logs longer than 4 m,  
3.6 m<sup>2</sup> for pulpwood shorter than 4 m.  
Load rating 11,000 kg.

### Engine

Perkins 1004-4T water-cooled turbocharged 4-cylinder diesel engine. Output 82 kW (111 hp)/2400 rpm. Max. torque 348 Nm/1600 rpm. Fuel tank 140 l.

### Transmission

Powershift transmission with Clark torque converter and low/high range; 2x3 speeds forward and reverse. Travel speed max. 25 km/h.

### Axles

Axles equipped with hydraulically operated differential locks. Balanced bogie at rear. Power transmission through gears in bogie beams. Disconnection of rear axle drive.

### Steering

Articulated frame steering with two steering cylinders. Steering angle  $\pm 40^\circ$ . Proportional steering with electric joystick.

### Tires

Front: 600-34 and rear 600-26,5, optional front 700-34 and rear 700-26.5.

### Brakes

Service and working brakes are hydraulically actuated, oil immersed multiple disc brakes. Spring actuated parking and emergency brakes.

### Hydraulic system

Load-sensing hydraulic system with power control. Working pressure 21 MPa. Pump capacity 240l/min. Hydraulic oil reservoir volume 110 l.

### Electrical system

Voltage 24 V. Batteries 2 x 105 Ah. Alternator 100 A/28 V. Halogen work lights 12 x 70.

### Loader

F71 F72  
Lift moment gross 99 kNm.  
Reach 7.2 m, optional 8.5 m.

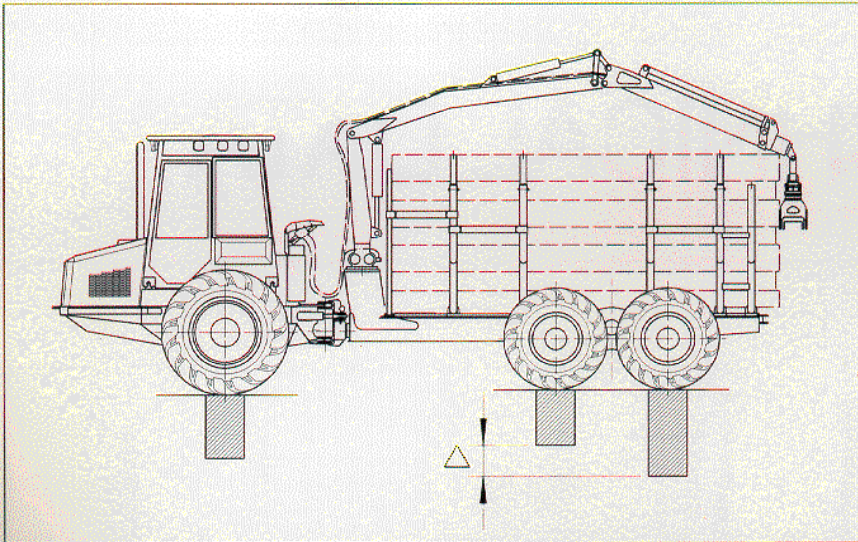

#### Cab

Spacious, light and comfortable cab gives the operator excellent visibility in all directions. Efficient heating and air-conditioning. Noise level ISO 5131: 1993 below 72 dB(A). Safety tested according to ISO standards. Radio/cassette recorder. Connection for cellular phone. Tinted polycarbonate windows.

#### Standard equipment

Tools. Operators' Manual. Spare Parts Catalogue. Fire extinguisher (if not Fire Extinguishing System.) Lock-up transmission. Stability brake. Engine oil extraction pump.

#### Optional equipment

Exhaust catalytic converter. Exhaust brake. Engine and cab preheater. Air cushioned seat. Electrical refill pump for hydraulics. Vacuum pump for hydraulics. Extra fire extinguisher. Fire Extinguishing System, night automatic. Tracks. Chains. Biodegradeable hydraulic oil. Steering wheel. Hydraulically moveable headboard.

All rights to alterations reserved.

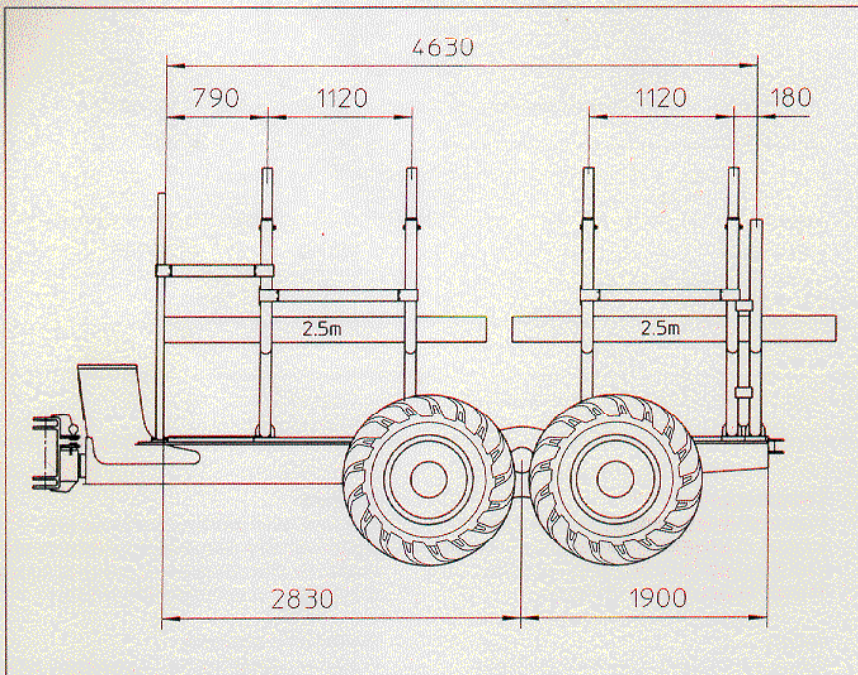

Timberjack Europe  
P.O. Box 474  
FIN-33101 Tampere, Finland  
Telephone int. +358 31 241 0111  
Telefax int. +358 31 241 0290

# Timberjack