

TIMBERJACK

1010B

FORWARDER

1010B

FORWARDER

1010B

FORWARDER

1010B

FORWARDER

Timberjack 1010B Forwarder

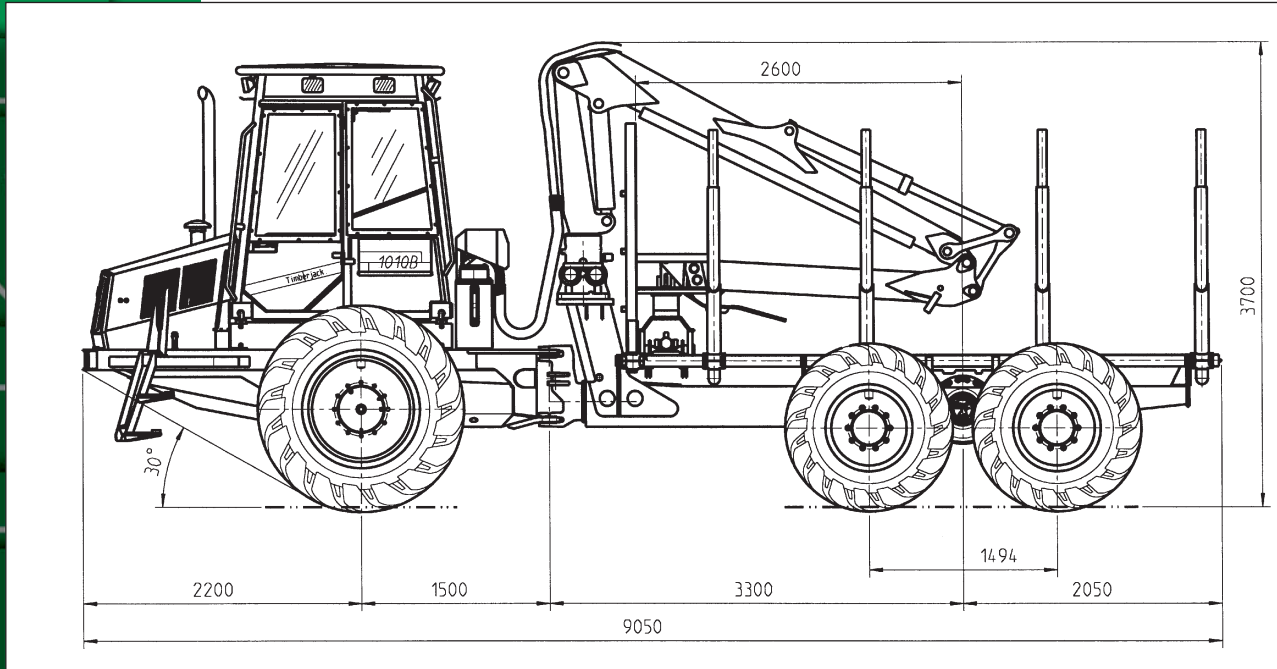

Technical Data

Dimensions

Length	9050 mm
Width (600 tires)	2700 mm
optional (700 tires)	2880 mm
Transportation height	3700 mm
Ground clearance	605 mm
Wheel base	4800 mm
Load rating	10,000 kg

Weight

Depending on options 12,100 – 13,150 kg

Load area

Length	4550 mm
Width	2660 mm
Cross sectional area	3.5 m ²
Hydraulically movable headboard, 4 bunks, 8 stakes	

Engine

Cummins 4BTA
Water-cooled 4-cylinder, turbo-charged and after-cooled diesel engine
Output 82 kW / 2200 rpm
Max. torque 445 Nm / 1500 rpm
Fuel tank capacity 140 l
A diesel rpm control system featuring mechanical work rpm control and a pedal for controlling the hydrostatic system and engine rpm.

Transmission

Hydrostatic-mechanical power transmission. Low and high range gearing. Power distributed between the front and rear axles. Off-road driving, smooth no-surge start. Release of rear-wheel drive. Travel speed max. 23 km/h. Max. tractive force 140 kN.

Axles

Portal type, gear bogie at rear. Hydraulically actuated mechanical differential lock in front and rear.

Steering

Articulated frame steering with two hydraulic steering cylinders. Proportional steering with electric joystick. Steering angle 44.

Tires

Front	600/65x34/14
(optional)	700x70x34/14
Rear	600/55x26.5/16
(optional)	700x26.5/16



Brakes

Service and working brakes are hydraulically actuated, oil immersed multiple disc brakes. Spring actuated parking and emergency brakes in front and rear bogies. Meets ISO 11169.

Hydraulic system

Timberjack Loader Control System (LCS) on loader. Load-sensing hydraulic system with power control.

Pressure	21.5 MPa
Pump displacement	100 cm ³ /r
Hydraulic oil reservoir	100 l

Electrical system

Voltage	24 V
Batteries	2 x 110 Ah
Alternator	70 A / 24 V
Working lights	14 x 70 W

Cab

Well-lighted and comfortable cab providing the operator excellent vision in all directions. The cab meets ISO standards for ROPS, FOPS and OPS. Due to the unique mounting of the cab, the noise level and vibrations are low. Noise level according to ISO 5131:1993 below 72 dB(A). The cab can be tilted for easy service access. Tinted polycarbonate windows. Air cushioned seat with air locked seat swivel. Efficient heating and air-conditioning. Radio/cassette receiver.

Notice!

Standard and optional equipment may vary. For details, contact your local dealer.

Standard equipment

Timberjack LCS (Loader Control System)
 Foldable mechanical steps
 Fire extinguisher ABE III / 6 kg
 Sprinkler system
 Stability brake
 Spark arrester
 Mineral hydraulic oil
 Mechanical refill pump for hydraulic oil
 Toolbox with service tools
 Spare Parts Catalogue/Operator's manual
 Working lights 2 x 70 W on loader

Optional equipment

Preheater, 5kW for engine and cabin
 Sun blinds in all windows
 Separate fuel tank 550 liters.
 Travel distance gauge
 Decking blade
 Steel wire branch protection
 Engine hood front protection
 Back-up alarm
 Chains
 Tracks
 Spare tire and wheel rim

Crane TJ 61 F

General

The slew torque for all types is 24.4 kNm with the angle 380 degrees and the gross lifting moment 91 kNm.

TJ 61 F 72	
Reach	7.2 m
Length of extension	1400 mm
Max. load at max. outreach	970 kg*

(Optional)	
TJ 61 F 85	
Reach	8.5 m
Length of extension	2650 mm
Max. load at max. outreach	700 kg*

(Optional)	
TJ 61 F 100	
Reach	10 m
Length of extension	4200 mm
Max. load at max. outreach	510 kg*

*) Without grapple, link and rotator

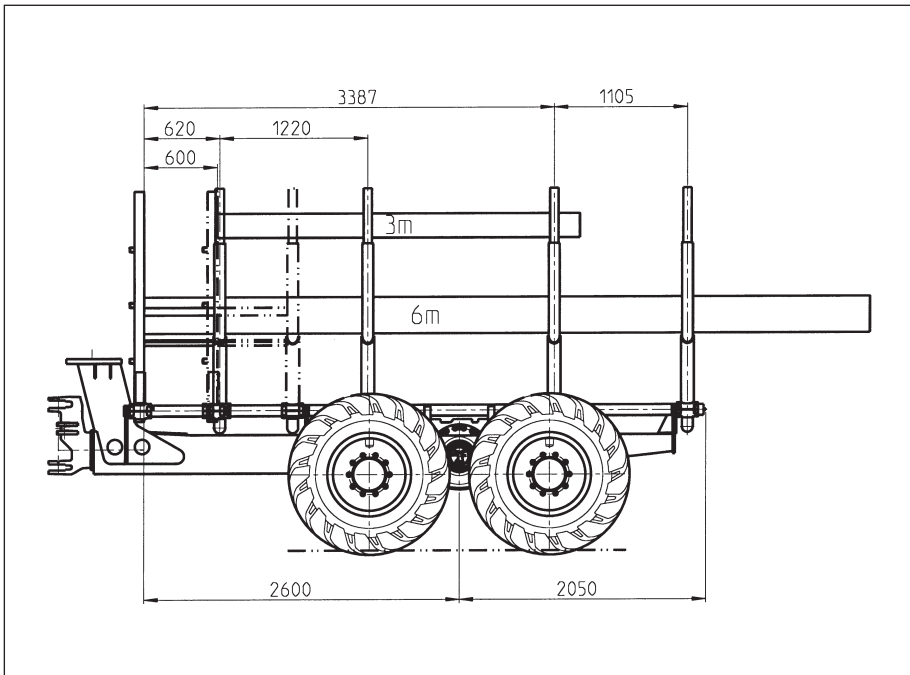

The manufacturer reserves the right to make changes or add improvements without incurring any obligation to make such changes on machines manufactured previously.

Timberjack

Doing more