



# 1910E



## John Deere 1910E forwarder: Ultimate speed and power for heavy-duty forwarding

Featuring enormous 19-metric-ton load capacity, powerful 9.0-liter and 186-kW (249 SAE hp) John Deere engine, and proven and powerful CF8 boom, the new John Deere 1910E Forwarder offers the ultimate choice for forwarding large loads rapidly over long distances. The 1910E is unbeatable in all heavy-duty applications and difficult conditions such as deep snow, steep slopes, and rocky ground. Revolutionary new features include a rotating and leveling cabin and TimberMatic™ automation for clear 360-degree visibility to your surroundings and to the boom for quicker, safer, and more ergonomic log loading. Additional comfort improvements like automatic air conditioning, high-quality upholstery, and lowered noise and vibration levels ensure an unparalleled operating experience.

The 1910E improves on its 1710D predecessor with over two additional tons of load capacity, 26 kW (35 SAE hp) more power, 40 cm<sup>3</sup> of increased work pump size, and 20 kN more tractive force. These up-grades make the 1910E, available in both six- and eight-wheel-drive versions, the most productive forwarder on the market. Smooth and accurate cabin leveling allows you to drive at higher speeds to get the job done faster. The VarioSpeed™ step-less transmission, an exclusive option for E-Series Forwarders, enables continuously smooth driving

and increases the wear life of all other powertrain components.

The 1910E is powered by a 9.0-liter John Deere PowerTech™ Plus engine with high torque at low rpm. Machine control and settings are easily adjusted through new TimberMatic F-09 automation – or when the machine is not PC-equipped through the CommandCenter™ control display. The unique John Deere TimberLink™ machine performance follow-up and optimization tool, now available for forwarders, enables you to

keep an eye on operating costs and track machine performance and efficiency.

All E-Series Forwarders are equipped with sturdier frames, and daily maintenance is reduced via the new hydraulic fan, which reverses automatically to clean dust and debris out of the engine cooler. The engine air filter enables pre-filtering, which increases the wear life of the filter. An optional central lubrication system further reduces the time needed for daily maintenance.

**THE REVOLUTIONARY E-SERIES.  
LOGGING WILL NEVER BE THE SAME AGAIN.**

[WWW.DEERE.COM/FORESTRYREVOLUTION](http://WWW.DEERE.COM/FORESTRYREVOLUTION)

# 1910E

## MEASUREMENTS \*

Length [A]	10 370 mm / 408 in.
Wheelbase [B+C]	5600 mm / 221 in.
Bogie center — Middle joint [B]	2000 mm / 79 in.
Middle joint — Bogie center [C]	3600 mm / 142 in.
Headboard — Bogie center [D]	2700 mm / 106 in.
Bogie center — Rear [E]	2100 mm / 83 in.
Width — 600 Series tires [F]	2920 mm / 115 in.
Width — 700 Series tires [F]	3120 mm / 123 in.
Turning angle	42°
Outer turning radius — 700 Series tires	9260 mm / 365 in.
Inner turning radius — 700 Series tires	5450 mm / 215 in.
Transport height	3900 mm / 154 in.
Load rating	19 tonnes / 20.9 short tons
Ground clearance 6W / 8W [G]	685 mm / 27 in. / 710 mm / 28 in.
Tires front 6W / 8W	34 - 16 / 26,5 - 20
Tires rear	26,5 - 20
Machine weight 6W / 8W	18,490 kg / 21,230 kg 40,763 lb. / 46,804 lb.
Approach angle 6W / 8W	29° / 42°

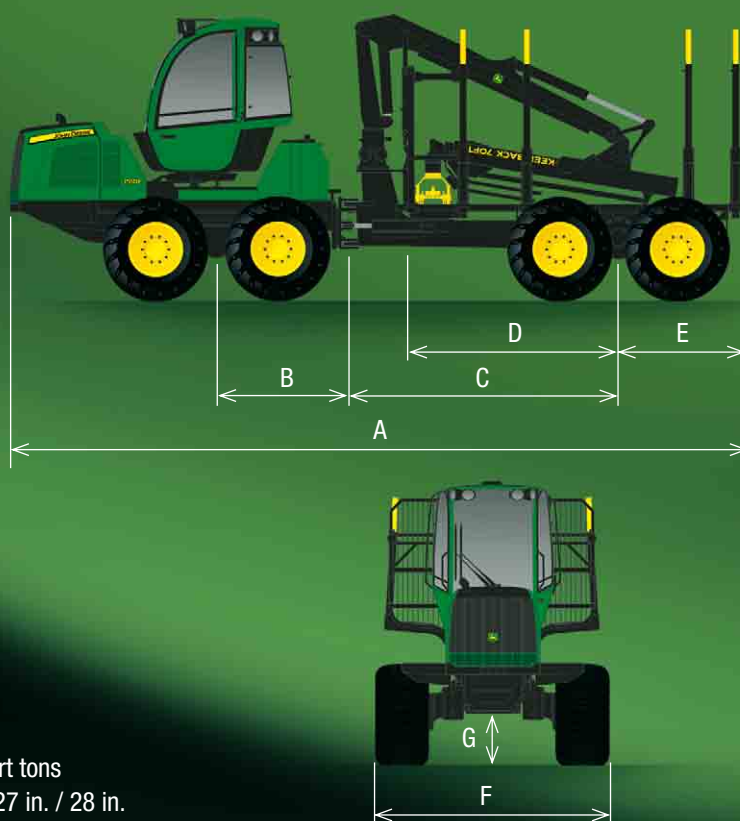

\* Note! The measurements are nominal and may vary depending on the manufacturing tolerances.

## BOOM

CF8	
Maximum reach	8.5 m / 27.9 ft.
Gross lifting torque	151 kNm / 111,372 lb. ft.
Gross slewing torque	41 kNm / 30,240 lb. ft.
Slewing angle	380°

## LOAD SPACE OPTIONS

Narrow standard/long,  
Wide standard/long, VLS, ALS

## DIESEL ENGINE

John Deere 6090, turbocharged, charge air cooled 6 cylinders, displacement 9.0 l / 549 cu.in.	
Maximum engine power	186 kW (1,900 rpm) / 249 SAE hp
Torque	1090 Nm @ 1,400 rpm / 804 lb. ft.
Fuel tank	184 l / 49 gal. U.S.

## WORKING HYDRAULICS

Load-sensing	
Pump size	180 cm <sup>3</sup> / 11 in <sup>3</sup>
Working pressure	24 MPa / 3,480 psi

## TRANSMISSION

Hydrostatic-mechanical, 2-speed gear box	
Axles / Bogies	Heavy-duty portal bogie axles with balancing system and diff lock
Tractive force	220 kN / 49,458 lbf.
Travel speed, gear 1	0-7 km/h / 0-4.4 mph
Travel speed, gear 2	0-21 km/h / 0-13.1 mph

## CAB

Rotating or Rotating and leveling	
Rotating angle	290°
Sideways tilt	10°
Forward/backward tilt	6°

## OPTIONAL EQUIPMENT

See your local dealer  
for availability

This brochure/literature has been compiled with care for worldwide circulation. While general information, pictures and descriptions are provided, some illustrations and text may include options and accessories not available in all regions. Please contact your local dealer for details.

John Deere reserves the right to change specification and design for products described in this brochure without notice.

No liability for errors and omissions.