

1510E



John Deere 1510E – Revolutionizing forwarder performance

With an efficient design and newly enhanced features, John Deere's E-Series forwarders give you more comfort, control and durability than ever before. The operating environment features a rotating and leveling cabin as well as new automation, so you can be more productive during the workday. With the cabin rotation, you'll have a 360 degree view of your surroundings – plus you can easily follow boom movements for safer, more ergonomic log loading. Add in comfort features like automatic air conditioning, high-quality upholstery, low noise and vibration levels, as well as a variety of other options for an unparalleled operating experience.

An increased load rating, added engine power and torque, and higher tractive force make the John Deere 1510E more productive than ever before. The new TimberMatic F-09 automation makes it easier to control the machine and set operator-specific parameters – or you can operate the forwarder through the CommandCenter™ control display. With smooth, accurate cabin leveling, you can drive at higher speeds to get the job done faster.

The 1510E is powered by a 6.8-liter John Deere PowerTech Plus™ engine with high torque at low rpm's. For top performance you can track, the 1510E comes equipped with an exclusive TimberLink™ machine performance follow-up and optimization tool, enabling you to keep an eye on operating costs and ultimately protect your investment.

All E-Series forwarders are equipped with frames sturdier than the corresponding D-Series machines – plus the 1510E also features heavy-duty bogie axles, so you don't have to back down when the jobs get tough. The new hydraulic fan reverses automatically cleaning dust and debris out of the engine cooler. The engine air filter includes pre-filtering which multiplies the filter lifetime. An optional central lubrication system further reduces the time spent on daily maintenance.

**THE REVOLUTIONARY E-SERIES.
LOGGING WILL NEVER BE THE SAME AGAIN.**

WWW.DEERE.COM/FORESTRYREVOLUTION

1510E

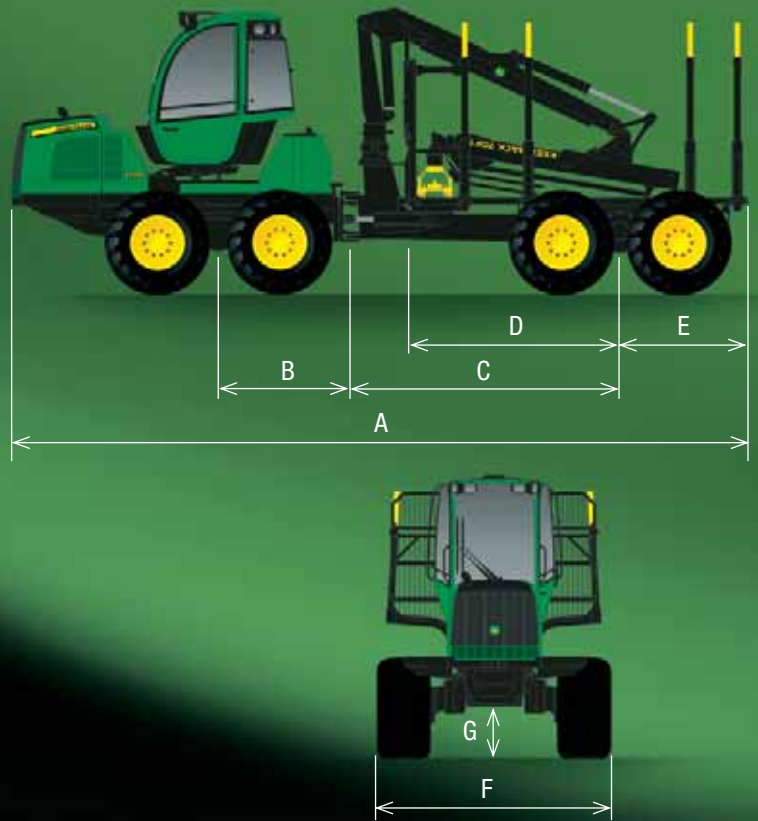

MEASUREMENTS *

Length [A]	9570 mm / 377 in
Wheel base [B+C]	5100 mm / 201 in
Bogie centre - Middle joint [B]	1700 mm / 67 in
Middle joint - Bogie centre [C]	3400 mm / 134 in
Head board - Bogie centre [D]	2600 mm / 103 in
Bogie centre - Rear [E]	1900 mm / 75 in
Width - 700 series tyres [F]	2950 mm / 117 in
Width - 800 series tyres [F]	3110 mm / 123 in
Turning angle	42°
Outer turning radius - 700 tyres	8550 mm / 337 in
Inner turning radius - 700 tyres	4840 mm / 191 in
Transport height	3800 mm / 150 in
Load rating	15 tonnes / 16.5 short tons
Ground clearance [G]	605 mm / 24 in
Tyres front 6W / 8W	34 - 14 / 26,5 - 20
Tyres rear	26,5 - 20
Machine weight 6W / 8W	16,900 kg / 17,900 kg 37,260 lbs / 39,460 lbs
Approach angle 6W / 8W	25° / 36°

* Note! The measurements are nominal and may vary depending on the manufacturing tolerances.

BOOM

CF7

Max. reach	7.2 / 8.5 / 10 m	23.6 ft / 27.9 ft / 32.8 ft
Gross lifting torque	125 kNm / 92,200 lbs ft	
Gross slewing torque	32 kNm / 23,600 lbs ft	
Slewing angle	380°	

LOAD SPACE OPTIONS

Narrow, Wide, VLS, ALS

DIESEL ENGINE

John Deere 6068,
Turbocharged, charge air cooled
6 cylinders, displacement 6.8 l

Max. engine power	145 kW (1900 rpm) / 195 hp
Torque	800 Nm @ 1300-1400 rpm / 590 lbs ft
Fuel tank	167 l / 44 gal

WORKING HYDRAULICS

Load-sensing
Pump size 140 cm³ / 8.5 in³
Working pressure 24 MPa / 3480 PSI

TRANSMISSION

Hydrostatic-mechanical,
2-speed gear box
Axles / Bogies Heavy-duty portal bogie axles with balancing system and diff lock
Tractive force 185 kN / 41,590 lbs
Travel speed, gear 1 0-7,5 km/h / 0-4.7 mph
Travel speed, gear 2 0-23 km/h / 0-14.3 mph

CAB

Rotating or Rotating and leveling
Rotating angle 290°
Sideways tilt 10°
Forward/Backward tilt 6°

OPTIONAL EQUIPMENT

Check availability from your local dealer