

1470E



John Deere 1470E – Ultimate productivity in harvesting

John Deere's E-series wheeled harvesters feature a completely new cabin and TimberMatic automation system. These together provide an operating environment where the operator remains fresh and productive throughout the work shift. The increased rotating and side tilt angles of the cabin, together with the more accurate and smoother movements of the cabin, give the operator greater visibility to the machine's surroundings and make working more enjoyable. The driving experience is completed with the new cabin's automatic air conditioning, high-quality upholstery, low noise and vibration levels, and the wide variety of optional features.

The new TimberMatic H-09 measuring and control system includes fully integrated machine diagnostics and bucking instructions, and ensures easy operation of the machine as well as easy setting of the operator specific parameters. In comparison to its predecessor, the John Deere 1470D, the 1470E also enhances productivity by its increased stability and maneuverability.

The 1470E is powered by a 9.0 liter John Deere PowerTech Plus™ engine which is characterized

by high torque at low rpm's, ensuring excellent fuel efficiency and power for processing large and heavy trees. The exclusive TimberLink™ software enables easy machine performance follow-up and optimization.

All E-series harvesters are equipped with completely new, stronger frames than the corresponding D-series machines. Uptime is enhanced by reduced need for daily and other checks and service actions. The new hydraulic fan reverses automati-

cally cleaning dust and debris out of the engine cooler. The engine air filter includes pre-filtering which multiplies the filter lifetime. An optional central lubrication system further reduces the time spent on daily maintenance.

1470E

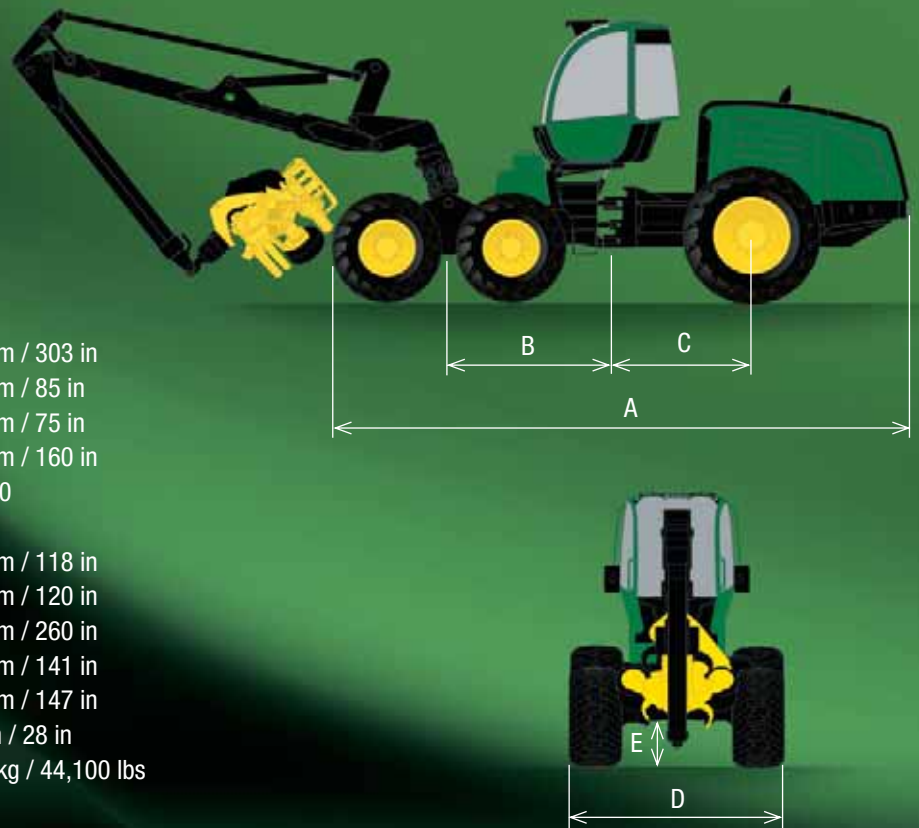

MEASUREMENTS *

Length [A]	7690 mm / 303 in
Front axle - middle joint [B]	2150 mm / 85 in
Rear axle - middle joint [C]	1900 mm / 75 in
Wheelbase [B+C]	4050 mm / 160 in
Tyres, front	26,5 - 20
Tyres, rear	34 - 16
Width - 650 series tyres [D]	2990 mm / 118 in
Width - 800 series tyres [D]	3050 mm / 120 in
Outer turning radius – 700 tyres	6590 mm / 260 in
Inner turning radius – 700 tyres	3580 mm / 141 in
Transport height	3730 mm / 147 in
Ground clearance [E]	710 mm / 28 in
Machine weight	20,000 kg / 44,100 lbs

* Note! The measurements are nominal and may vary depending on the manufacturing tolerances.

BOOM

CH8	
Gross lifting torque	210 kNm / 154,900 lbs. ft.
Slewing torque	55 kNm / 40,570 lbs. ft.
Max. reach	8.6 / 10 / 11 m 28.2 ft / 32.8 ft/ 36.1 ft
Slewing angle	220°
Tilt angle, backwards / forwards	-15 / +28°

HARVESTER HEAD OPTIONS

H480, 758HD, H270, H290

DIESEL ENGINE

John Deere 6090HTJ	
Turbocharged, charge air cooled	
6 cylinders, displacement 9.0 l	
Max. engine power	190 kW (1900 rpm) / 255 hp
Torque	1250 Nm @ 1400 rpm / 920 lbs. ft.
Fuel tank	435 l / 115 gal

WORKING HYDRAULICS

Load-sensing	
Pump size	210 cm ³ / 12.8 in ³
Working pressure	24/28 MPa / 3480/4060 PSI

TRANSMISSION

Hydrostatic-mechanical, 2-speed gear box	
Axles / Bogies	Hydromechanical differential lock at the front and the rear
Front	Balanced portal bogie
Rear	Single rigid axle
Tractive force	180 kN / 40,470 lbs
Steering angle	44°

CAB

Leveling and rotating (std), fixed cab (option)	
Side tilt	0 - 17°
Front/back tilt	0 - 10°
Rotating angle	160°

MEASURING AND CONTROL

Timbermatic H-09

OPTIONAL EQUIPMENT

Check availability from your local dealer