

1110E



John Deere 1110E – World's favorite all-round forwarder

With its increased power and pulling force as well as a totally new operating concept, the John Deere 1110E forwarder gives you more comfort, control and durability than ever before. This all-round forwarder comes with the proven CF5 boom and 12 tons load capacity, making it ideal for those customers demanding versatility to complete both thinning and clearfell operations. The new, revolutionary operating concept features a rotating and leveling cabin as well as new TimberMatic™ automation. With cabin rotation, you'll have clear, 360-degree visibility of your surroundings and can easily follow boom movements for safer, more ergonomic log loading. Additional comfort features like automatic air conditioning, high-quality upholstery, low noise and vibration levels, as well as a variety of other options, ensure an unparalleled operating experience.

Compared to its D-series predecessor, the 1110E is equipped with larger work and transmission pumps for improved performance and pulling force. The smooth and accurate cabin leveling allows you to drive at higher speeds to get the job done faster, while reducing operator fatigue. The VarioSpeed™ stepless transmission is an exclusive option for the E-Series forwarders. It provides continuous, smooth driving and increases the lifetime of all other power train components.

The 1110E is powered by a 6.8-liter John Deere PowerTech Plus™ engine with high torque at low rpm's. Machine control and settings are easily adjusted through the new TimberMatic F-09 automation — or when the machine is not equipped with a PC, through the CommandCenter™ control display. John Deere's unique TimberLink™ machine performance follow-up and optimization tool is now available for forwarders, too, and will enable you to keep an eye on operating costs and to track the performance and efficiency of your machine.

All E-Series forwarders are equipped with frames sturdier than the D-Series machines. Daily maintenance is reduced through the new hydraulic fan which reverses automatically cleaning dust and debris out of the engine cooler. The engine air filter includes pre-filtering which multiplies the filter lifetime. An optional central lubrication system further reduces your time need for daily maintenance.

THE REVOLUTIONARY E-SERIES.
LOGGING WILL NEVER BE THE SAME AGAIN.

WWW.DEERE.COM/FORESTRYREVOLUTION

1110E

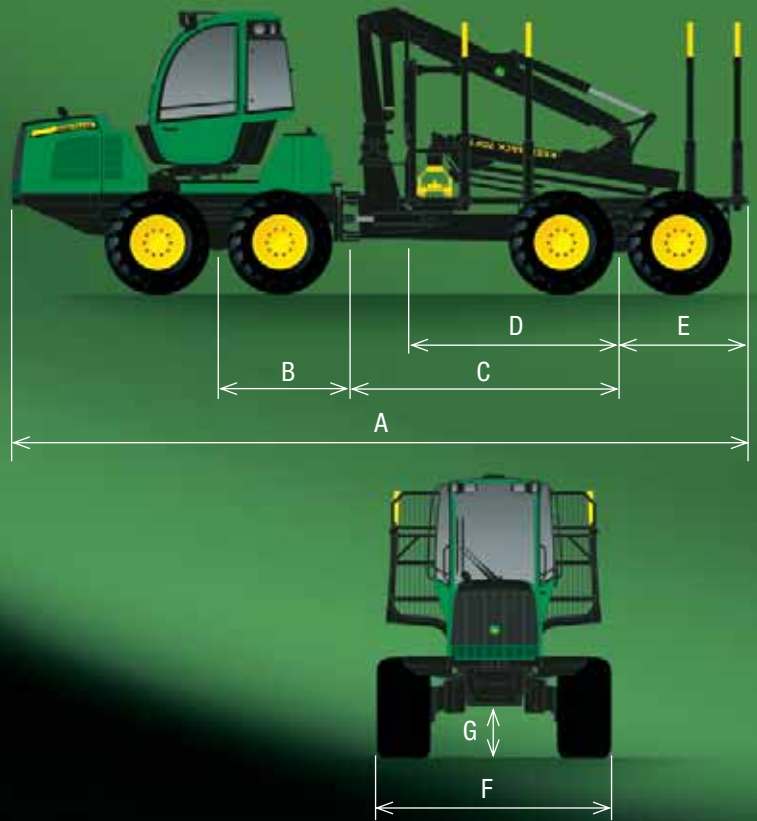

MEASUREMENTS *

Length [A]	9570 mm / 377 in
Wheel base [B+C]	5100 mm / 201 in
Bogie center - Middle joint [B]	1700 mm / 67 in
Middle joint - Bogie center [C]	3400 mm / 134 in
Head board - Bogie center [D]	2600 mm / 103 in
Bogie center - Rear [E]	1900 mm / 75 in
Width - 600 series tires [F]	2700 mm / 106 in
Width - 700 series tires [F]	2890 mm / 114 in
Turning angle	44°
Outer turning radius - 700 tires	8243 mm / 325 in
Inner turning radius - 700 tires	4493 mm / 177 in
Transport height	3800 mm / 150 in
Load rating	12 tonnes / 13.2 short tons
Ground clearance [G]	605 mm / 24 in
Tires front 6W / 8W	34 - 14 / 26,5 - 20
Tires rear	26,5 - 20
Machine weight 6W / 8W	15,500 kg / 17,300 kg 34.170 lbs / 38.140 lbs
Approach angle 6W / 8W	25° / 36°

* Note! The measurements are approximate and may vary depending on the manufacturing tolerances.

BOOM	CF5
Max. reach	7.2 / 8.5 / 10 m 23.6 ft / 27.9 ft / 32.8 ft
Gross lifting torque	102 kNm / 75,235 lbs ft
Gross slewing torque	24 kNm / 17,700 lbs ft
Slewing angle	380°

LOAD SPACE OPTIONS	Narrow, Wide
---------------------------	--------------

DIESEL ENGINE	John Deere 6068, Turbocharged, charge air cooled 6 cylinders, displacement 6.8 l
Max. engine power	136 kW (1900 rpm) / 183 hp
Torque	780 Nm @ 1400 rpm / 575 lbs ft
Fuel tank	167 l / 44 gal

WORKING HYDRAULICS	Load-sensing
Pump size	140 cm ³ / 8.5 in ³
Working pressure	24 MPa / 3481 PSI

TRANSMISSION	Hydrostatic-mechanical, 2-speed gear box
Axles / Bogies	Portal bogie axles with balancing system and diff lock
Tractive force	160 kN / 35,970 lbs
Travel speed, gear 1	0-7,5 km/h / 0-4.7 mph
Travel speed, gear 2	0-23 km/h / 0-14.3 mph

CAB	Rotating or Rotating and leveling
Rotating angle	290°
Sideways tilt	10°
Forward/Backward tilt	6°

OPTIONAL EQUIPMENT	Check availability from your local dealer
---------------------------	--